

Assembly, Installation, and Operation Instructions for RPK1-N/A for use with 36" or larger F, FX, DF, DFX, CS (Natural Gas) or FA, FA-X, DFA, DFA-X, CA (Propane Gas) Burners

ATTENTION! READ INSTRUCTIONS CAREFULLY BEFORE ASSEMBLY.

Required Tools and Materials: Adjustable Wrench, Pipe Wrench, Screw Driver, Phillips Screw Driver, Pipe sealing compound (only required if fittings not already prepared with pre-wrapped Teflon thread tape).

RPK1 Parts List: (Note: Assembly of this accessory also requires fittings included with the Burner Pan)

All Models: <ul style="list-style-type: none"> Valve Pilot Thermogenerator with pilot tubing and thermopile leads. Pilot Support bracket 	<ul style="list-style-type: none"> Heat Shield 10" Aluminum Connector 20' length wire (20 AWG Type CL2) 1 10-32 x 3/8 nut 3 10-32 x 3/8 bolts 	<ul style="list-style-type: none"> F2 3/8 Flared x 1/2 MIP 	LP Gas Models <ul style="list-style-type: none"> 3 Burner orifices (#45, #49 and #53) 1 1/2 x 3/8 Air Mixer NOTE: Air mixer must be used on all LP models.
---	--	---	--

Suggested Firebox Layout and Required Parts: Pilot Control Valves are adversely effected by heat. The best protection is afforded by placing the safety control valve assembly outside the firebox (Figure 1). If the valve is placed inside the firebox, it must be placed as far forward and to the side of the burner pan as possible (Figure 2).

NOTE: If it is not possible to enclose the control valve inside a separate vault the valve must be shielded from heat and fire. Use the provided Heat Shield and position the valve to prevent direct heat radiation to the control valve. Heat shields can also be constructed of brick and/or metal with fiberglass insulation material. The design of the shield should prevent direct heat radiation to the control valve.

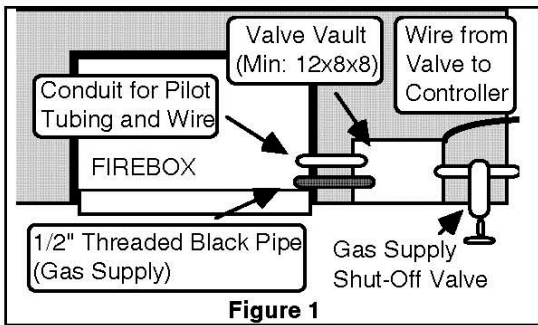

RPK1 Valve Placement Options (as viewed from above)
 ← Valve Assembly outside firebox.
 Forward and to the Side of the burner pan. →

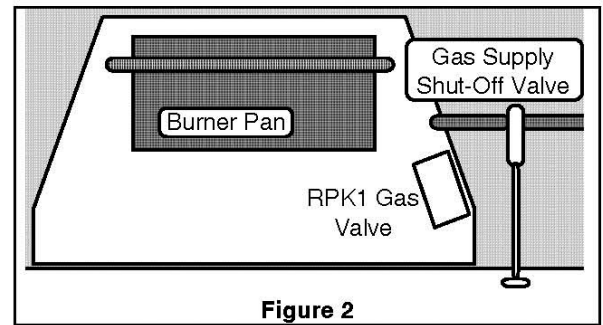

ASSEMBLY: (Note: If fittings do not come pre-wrapped with Teflon threaded tape, pipe compound must be applied to the non-flared input threads).

STEP ONE: Burner Pan Fittings (Figure 3).

1. Ensure that **Burner Plug** (provided with Burner Pan) is inserted into opposite end of burner pipe (see Burner Pan Instructions) and wrench tighten.
2. Thread the **NAT Gas or LP Gas Burner Pan Inlet Assembly** into burner pan.

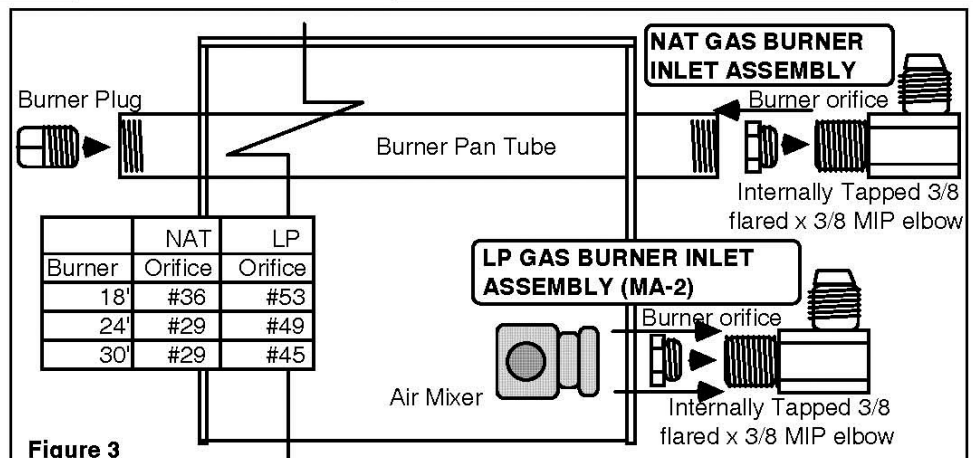

- **Natural Gas Burners** (F, FX, CS) Insert the appropriate **Burner Orifice** (see chart at Figure 3) into the **Internally Tapped 3/8 Flared x 3/8 MIP Elbow** and wrench tighten. (Orifice and Fitting are provided with Burner Pan).
- **Propane Gas Burners** (FA, FA-X, CA) requires **MA-2 Air Mixer Assembly** (see Figure 3). Insert the appropriate **Burner Orifice** (see chart at Figure 3) into the **Internally Tapped 3/8 Flared x 3/8 MIP Elbow** and wrench tighten. Thread the **Air Mixer** onto the **3/8 Flared x 3/8 MIP Elbow** and wrench tighten with air intake holes positioned horizontally (parallel to the floor). **LP Models must use the MA-2 Air Mixer Assembly.**

STEP TWO: Attach Pilot (Figure 4).

1. With the **Pilot Thermo-generator** beneath the **Pilot Support Bracket**, insert the **10-32 Bolts** through the drilled-holes in **Pilot Support Bracket** into the threaded holes of the **Pilot Thermo-generator Assembly**. Tighten with Screw driver.
2. Insert **10-32 Bolt** through the **Pilot Support Bracket** and pre-drilled hole in back of Burner Pan (side of CS/CA pan-see "**CS/CA Burner Pan Side View**" at Figure 4). Thread **10-32 Nut** onto the 10-32 Bolt and tighten. Ensure that **Pilot Burner** is centered over **Burner Tube**.

NOTE: To ensure proper operation, **Pilot** and **Pilot Support Bracket** must be installed as depicted

3. Route **Pilot Tubing** and **Thermopile Leads** to Control Valve location.

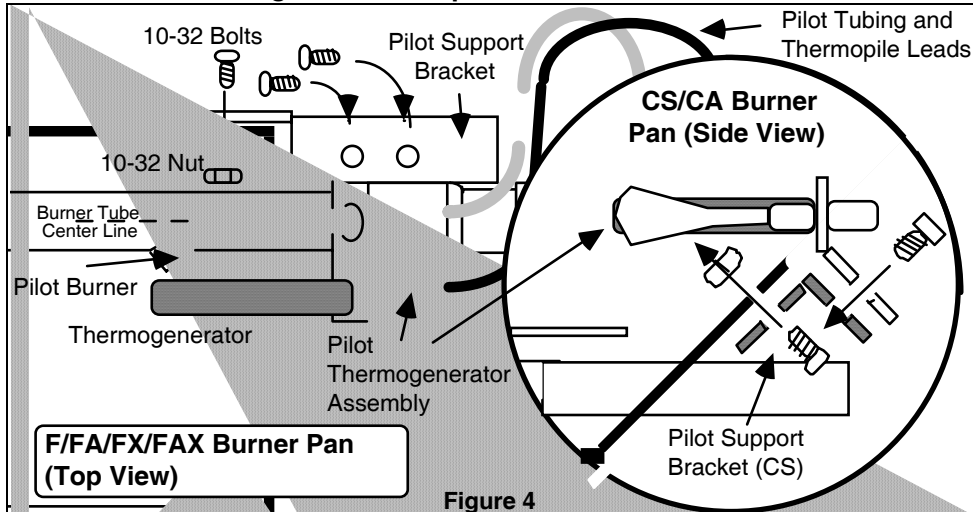

Figure 4

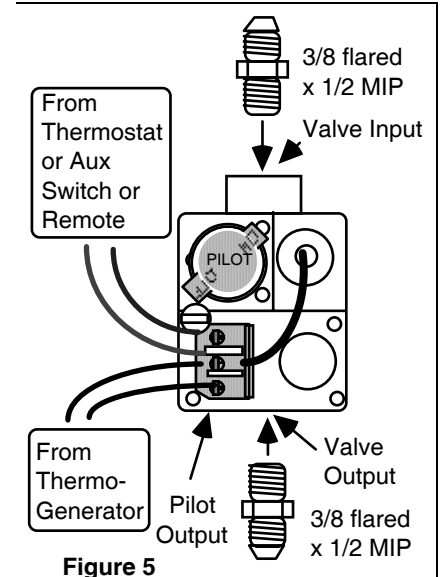

Figure 5

STEP THREE: Valve Fittings (Figure 5).

1. Thread the **3/8 FIP x 1/2 MIP** fittings into the Inlet and Outlet sides of the valve and wrench tighten.

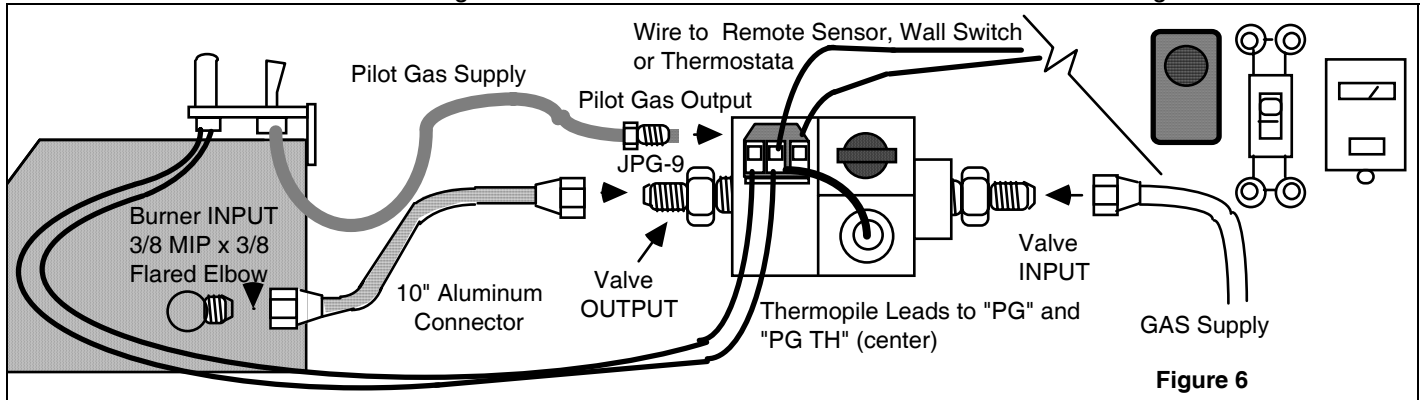

Figure 6

STEP FOUR: Connect Burner and Pilot Gas Supply (Figure 6).

1. Connect **10 inch Aluminum Connector** between the flared ends of the valve output **3/8 Flared x 1/2 MIP** and the burner input **3/8 Flared x 3/8 MIP Elbow** (Note: do not use pipe compound on flared fittings-wrench tighten only). Bend the **10 inch Aluminum Connector** to obtain the optimum **Valve** position (**Forward and to the side of the burner pan.** (Figures 1 and 2).
2. Thread (using no pipe compound) the **JPG-9 Pilot Input Fitting** into valve **Pilot Output** and wrench tighten.

STEP FIVE: Connect Thermopile and Controller Wiring:

1. Attach the **JPG-9 Thermo-generator Leads** to the "**PG**" and "**PG TH**" terminals of the **Valve Terminal Block**. See Figures 5, 6 and 7.
2. Connect the **Accessory Wiring** (tab ends) to the two "**TH**" and "**PG TH**" terminals of the **Valve Terminal Block** as shown in Figure 7.

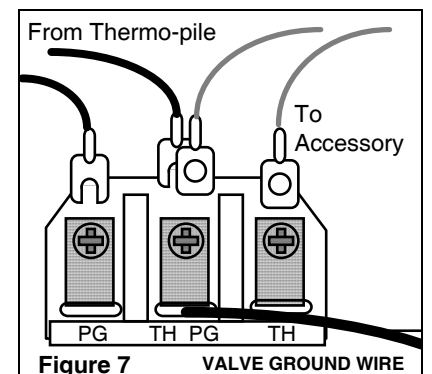

Figure 7

CAUTION: This is a millivolt system. **DO NOT** connect to 115 V line. **Safety controls damaged by heat or 115 volt electricity are not covered by warranty.**

NOTE: Thermostat wiring is 20 AWG Type CL2. Electrical resistance for wire lengths greater than 20 feet may exceed the Thermo-generator's ability to operate correctly.

STEP SIX: Install Heat Shield.

Place the **Heat Shield** on the valve with the notched vertical face between the Valve and the Burner Pan. Ensure that the **Heat Shield** is over the **Valve Assembly** as shown in Figure 8

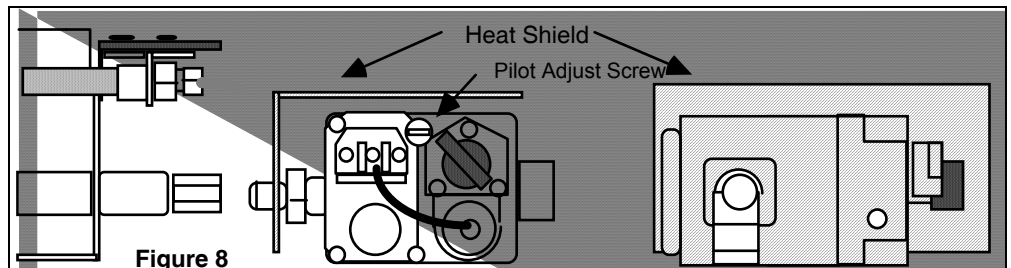

WARNING! HEAT SHIELD MUST BE INSTALLED TO PREVENT PREMATURE VALVE FAILURE AND/OR VOIDING OF VALVE MANUFACTURER'S WARRANTY

CAUTION: The safety control valve must be protected to a max ambient temperature of 175° F. Excessive heat to the valve is indicated by melted plastic on the valve body.

STEP SEVEN: Connecting Accessory Controller:

Using the 20' accessory control wiring attached to the two **outside terminals** of the **Valve Terminal Block** (see Figures 6 and 7), connect the **Switch Control Accessory Option** (Remote, Thermostat, Switch, etc.) to valve.

CAUTION: This is a millivolt system. DO NOT connect to 115 V line. Safety controls damaged by heat or 115 volt electricity are not covered by warranty.

Switch Control Accessory Options:

ULTRA-SONIC WIRELESS REMOTE	(Model "F10-AB")
INFRARED WIRELESS REMOTE WITH THERMOSTAT	(Model "IRRC")
WALL SWITCH	(Model "WS-1")
WALL THERMOSTAT	(Model "TS-1")
WALL TIMER (60 MINUTE TIMER)	(Model "WT-1")
CRACKLER Sound Generator option for F10 AB or IRRC	(Model "CF5")

- Accessory **REMOTE LOG HOUSE (Model "RH")** is available for use as a heat resistant "log" in which the receiver portion of Wireless remote option **F10 AB** or **IRRC** may be located.
- Accessory **CRACKLER LOG HOUSE (Model "CH")** is available for use as a heat resistant "log" in which the **CRACKLER** Sound Generator option for both the **F10 AB** and **IRRC** wireless remotes may be located.

LIGHTING

CAUTION! DAMPER AND GLASS DOORS MUST BE FULLY OPEN BEFORE LIGHTING OR BURNING FOR PROPER VENTILATION AND TO PREVENT HEAT DAMAGE TO VALVE

F, FX & CS burners use Natural Gas. Fill Burner Pan with the white sand provided with burner. FA, FA-X & CA burners use LP Gas. Fill Burner Pan with black volcanic ash provided with burner.

STEP ONE: Pilot Lighting:

NOTE: The **Gas Dial** has complete control of gas to pilot and burner. The **Gas Dial** cannot be turned to "OFF" without first depressing dial in "**PILOT**" position and then rotating clockwise to "**OFF**". (see Figure 7)

1. Depress and turn **Gas Dial** to "**OFF**" position. (Figure 9)
2. Set Accessory Control to "**OFF**" (Remote Control) or to lowest temperature setting (Thermostat)
3. Wait at least 5 minutes to allow gas which may have accumulated around burner to escape.
4. Turn **Gas Dial** to "**PILOT**" position. (Figure 9)
5. Depress and hold **Gas Dial** until air is bled and gas flows to pilot.
6. Light pilot. Continue to hold in the **Gas Dial** until the Pilot flame remains lit when knob is released (approximately 60 to 90 seconds). If Pilot does not remain lit, repeat steps 1 through 5 and allow more time after Pilot Lighting before releasing knob.
7. Turn **Gas Dial** to "**ON**". (Figure 9)

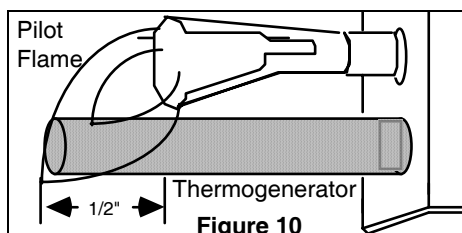
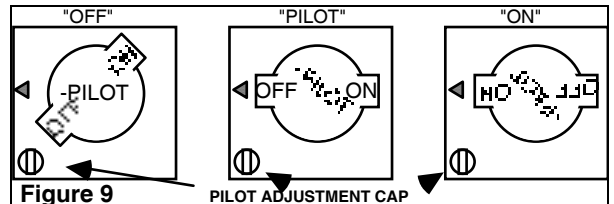

STEP TWO: Pilot Adjustment

1. The **PILOT FLAME** should be steady and soft blue surrounding approximately 1/2 inch of the thermocouple tip (see Figure 10).
2. If pilot flame adjustment is necessary, use a narrow long stem screw driver to turn **PILOT ADJUST SCREW**. The **PILOT ADJUST SCREW** is located on the Gas Valve (see Figure 9). Turn clockwise for less flame, counter clockwise for more flame.

OPERATION

IMPORTANT! CHIMNEY DAMPER MUST BE WIDE OPEN

**CAUTION! DAMPER AND GLASS DOORS MUST BE FULLY OPEN BEFORE LIGHTING OR BURNING FOR PROPER VENTILATION AND TO PREVENT HEAT DAMAGE TO VALVE.
THE FLUE MUST VENT ALL PRODUCTS OF COMBUSTION.**

Burner ON or OFF (Switch and Remote Valve):

With the **Gas Dial** (Figure 9) in the "ON" position, place the **Wall or Remote Switch** to "ON" or raise the **Thermostat Setting** (Thermostat). To turn burner off (pilot remains lit) place **Wall or Remote Switch** to the "OFF" position or to the lowest **Thermostat Setting** (Thermostat).

Adjusting Burner Flame Height:

Flame size at the burner is adjustable at the **Gas Dial** (Figure 9). Turn **Gas Dial** counter clockwise for more flame, clockwise for less flame.

Switch Operation: Place manual switch in the "ON" position (Figure 9).

Remote Operation:

Place Remote Receiver switch in the "REMOTE" position. (Figure 10) Burner on or off is now "Remotely Controlled" by the Remote Transmitter. Individual operating instructions for each Accessory Option are included with the individual accessory.

Complete Shutdown (Including Pilot):

Place **Accessory Control Switch** position to "OFF" or **Thermostat Control** to the lowest setting. Slightly push and turn **Gas Cock Dial** to "OFF". (Figure 9)

(Remote Model) Operation Of Ultrasonic Remote Control

Before you start: Both the transmitter and receiver require 9 volt batteries to operate in remote control. The blue and black receiver wire leads are for the optional sound producing device (CRACKLER). The receiver must be protected from overheating. Locate receiver well away from heat.

Accessory **REMOTE LOG HOUSE (Model "RH")** is available for use as a heat resistant "log" in which the receiver may be located.

Operation Tips: This is a sound operated remote (unlike TV remotes which are Infrared and operate instantly) and requires you to **aim and hold** the transmitter for **1 to 3 seconds** to operate.

Manual Operation: (Receiver switch position ON or OFF) does not require batteries.

Remote Operation: Requires good batteries. If you turn the gas log on using the remote control and then turn the set off by sliding the receiver switch from REMOTE to OFF, when you replace the switch to REMOTE it will remain in the last selected remote position (in this case ON) and turn the gas log on.

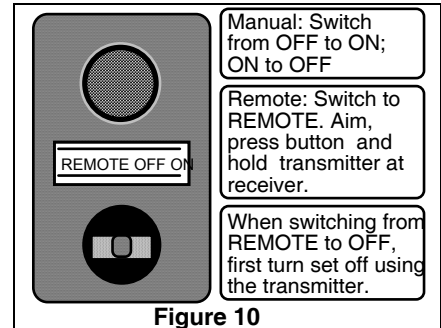

IMPORTANT!: To shutdown overnight or for any prolonged period, slide receiver switch to "OFF".

ATTENTION:

Your Gas Log set should be operated for the first 2-3 hours at a low flame setting to allow tempering of the refractory logs.

WARNING: NEVER OPERATE YOUR GAS LOG WITH GLASS DOORS CLOSED. ALLOW AN ADEQUATE PERIOD OF COOLING AFTER USE BEFORE CLOSING GLASS DOORS.

CAUTION: This is a millivolt system. **DO NOT** connect to 115 V line. **Safety controls damaged by heat or 115 volt electricity are not covered by warranty.**

CAUTION! DAMPER AND GLASS DOORS MUST BE FULLY OPEN BEFORE LIGHTING OR BURNING FOR PROPER VENTILATION AND TO PREVENT HEAT DAMAGE TO VALVE

WARNING! Heat Shield must be installed to prevent premature valve failure and/or voiding of valve manufacturer's warranty

CAUTION: The safety control valve must be protected to a max ambient temperature of 175° F. Excessive heat to the valve is indicated by melted plastic on the valve body.

IMPORTANT!: To shutdown overnight or for any prolonged period, slide receiver switch to "OFF".

